



Kymeta™ u8 Products Installation and User Guide

Covers u8 terminal and u8 ODU configurations

Document number: 700-00121-000 rev G

17 May 2021

Table of contents

1	Introduction and general considerations	4
1.1	Reduce the risk of RF exposure	5
1.2	Prevent RF interference	5
1.3	Prevent magnetic interference	5
1.4	Check electrical systems for safety	5
1.5	Site selection	5
1.6	Mounting considerations	7
1.7	Land-mobile installation considerations	7
1.8	Supported browser	7
1.9	QR code	8
2	u7-to-u8 upgrade kit installation considerations	9
2.1	Physical and mounting considerations	9
2.2	Cabling considerations	10
2.3	Power considerations	10
2.4	u7 product disposal	10
2.5	u7 product warranty	10
3	Unbox the u8 terminal	11
4	Open the u8 shroud	12
5	Install the u8 terminal	13
5.1	Get the u8 terminal ready	13
5.1.1	Mobile platform instructions	13
5.1.2	AC power source instructions	13
5.2	Mount the u8 terminal	13
5.2.1	Mobile platform instructions	13
5.2.2	Stationary platform instructions	13
5.3	Power on the u8 terminal and access the antenna	14
5.4	Provision and commission the u8 terminal with Kymeta™ Broadband services	15
5.4.1	Provision and commission the u8 terminal without Kymeta™ Broadband services	15
5.5	Set up the u8 terminal secondary SIM	16
6	Install the u8 ODU	17
6.1	Connect the cables to the u8 ODU	17
6.2	Mount the u8 ODU	17
6.3	Power on the u8 ODU and access the antenna	18
6.4	Provision and commission the u8 ODU	18

7	Obtain u8 antenna status information	19
7.1	Open the shroud access panel	20
8	Set up u8 antenna orientation	21
9	Network interfaces	23
10	Manage u8 antenna automatic reboot	26
11	Manage over-the-air (OTA) updates	26
11.1	OTA update process	26
11.2	Software rollback	26
12	Troubleshoot the u8	27
13	Replace components	27
14	Clean the u8	28
14.1	General cleaning	28
14.2	General cleaning agents	28
14.3	Hydrophobic coating reapplication	28
15	Package the Kymeta u8 terminal	29
16	Customer support	30
17	Revision history	30
18	Copyright and trademark information	30
	Appendix A. Kymeta u8 terminal cabling diagram	31
	Appendix B. Kymeta u8 ODU cabling diagram	33
	Appendix C. LED status indicators	35
	Appendix D: u8 accessories available for purchase	37
	Appendix E: u8 ODU and u8 terminal parts available for purchase	38
	Appendix F: Device login information	39

1 Introduction and general considerations

This document contains important step-by-step details for the installation and setup of the Kymeta™ u8 terminal and Kymeta™ u8 outdoor unit (ODU). Read this document in its entirety.

For information on the Kymeta u8 antenna web-based user interface, refer to *700-00139-000 Kymeta™ u8 antenna software user guide*.

For your safety, read *700-00122-000 Kymeta™ u8 products safety and handling guide* before beginning installation.

✎ This document also contains important u7-to-u8 terminal upgrade considerations.

Refer to [2 u7-to-u8 upgrade kit installation considerations](#) for details.

Before starting installation, acquire all the hardware and tools required for u8 terminal installation. Installation tools are not provided with the product. If you ordered any u8 accessory kit(s) to accompany your u8 terminal or u8 ODU, refer to the installation instructions shipped with the kit(s).

During installation, avoid obstructing the air intake screens or drain holes.

✎ Never grab or lift the u8 by the shroud, diplexer or any other part of the RF chain. Never use the diplexer or any part of the RF chain to mount the ODU as they are not a structural part of the u8 and may be damaged if handled improperly. Avoid damaging the coating on the diplexer. Use the corner handles to lift the u8.

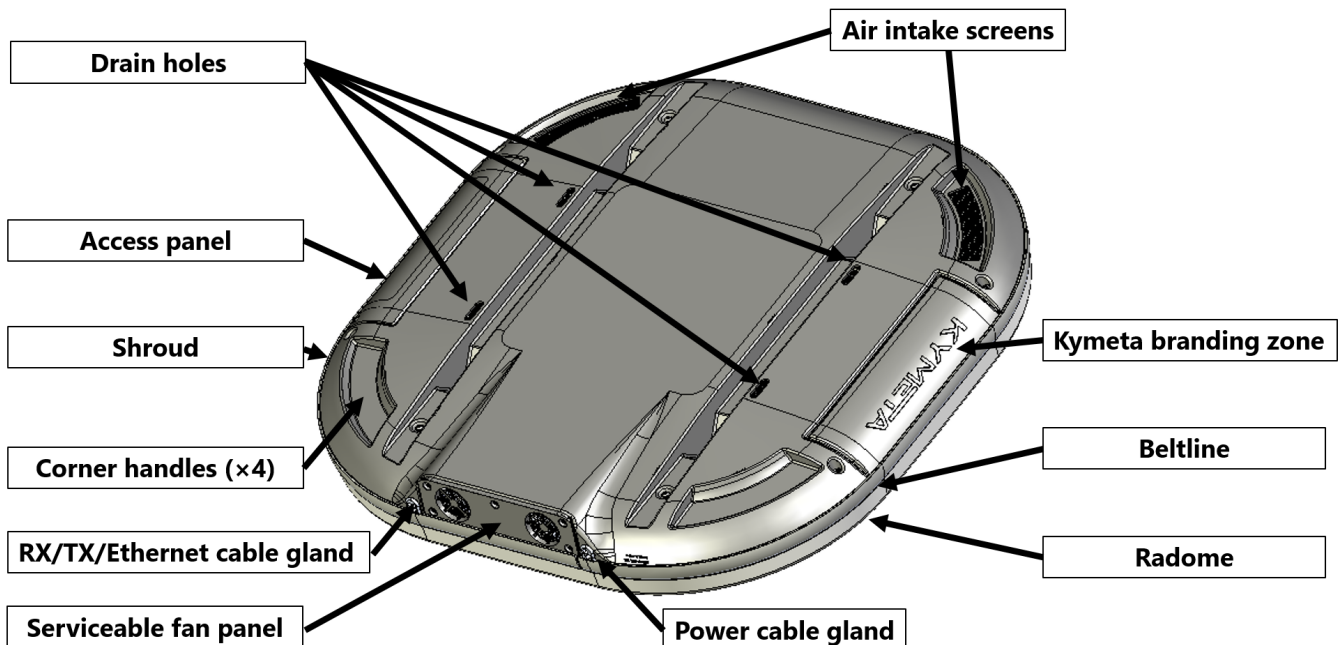

Figure 1. u8 terminal and u8 ODU external guide

1.1 Reduce the risk of RF exposure

Install the u8 ODU or u8 terminal in an area above accessible range of personnel within the operational range of the antenna to reduce the risk of RF exposure. Mount the terminal in an area that has limited access by people and does not allow for people to pass through the path of the antenna beam in any direction the antenna beam may point. Hazard zones can be set up on the antenna to prevent transmitting at specific angles relative to the antenna. Refer to *700-00139-000 Kymeta™ u8 antenna software user guide*, section "Set up hazard zones" for more information.

u8 terminals operating under Kymeta FCC blanket authorization (call sign: E170070) must limit BUC output power to 42.3 dBm to maintain compliance with RF safety labeling on the unit ensuring general public safety during transmit operations. Limiting BUC output power and mounting above the human users or appropriately marking a keep-out area ensure safe exposure limits for all users.

1.2 Prevent RF interference

Do not install the u8 ODU or u8 terminal closer to radar equipment than the minimum safe distance specified in the *700-00122-000 Kymeta™ u8 products safety and handling guide*. It may cause damage to the ODU.

1.3 Prevent magnetic interference

Proximity to magnetic interference caused by motors, fans, or ferrous metals may increase acquisition times. Install the u8 ODU or u8 terminal as far as possible from any equipment or materials that may cause magnetic interference for faster acquisition times.

1.4 Check electrical systems for safety

Prior to installation, check that:

- » the ODU or terminal is grounded;
- » the electrical power is disconnected from the ODU or terminal; and
- » in an ODU configuration, electrical connections are made to the ODU first and then to the modem.

Practice basic electrical safety measures. Follow local, national, and other regulations with respect to these devices.

1.5 Site selection

- » Obstructing the direct path to the satellite degrades performance and may cause a loss of connection with the satellite. The antenna should have a clear line of sight: 15° – 90° elevation (broadside to 75° scan angle), full 360° azimuth (broadside to 75° scan angle).
- » Obstructing the face of the antenna degrades RF performance and could impair the GNSS capability of the antenna.
- » Satellite reacquisition is most efficient if you install the antenna in direction of travel; refer to [8 Set up u8 antenna orientation](#) for more details.

 If you need support in assessing your mounting configuration, contact Kymeta customer support at support@kymetacorp.com for additional information.

The following images show example installation sites.

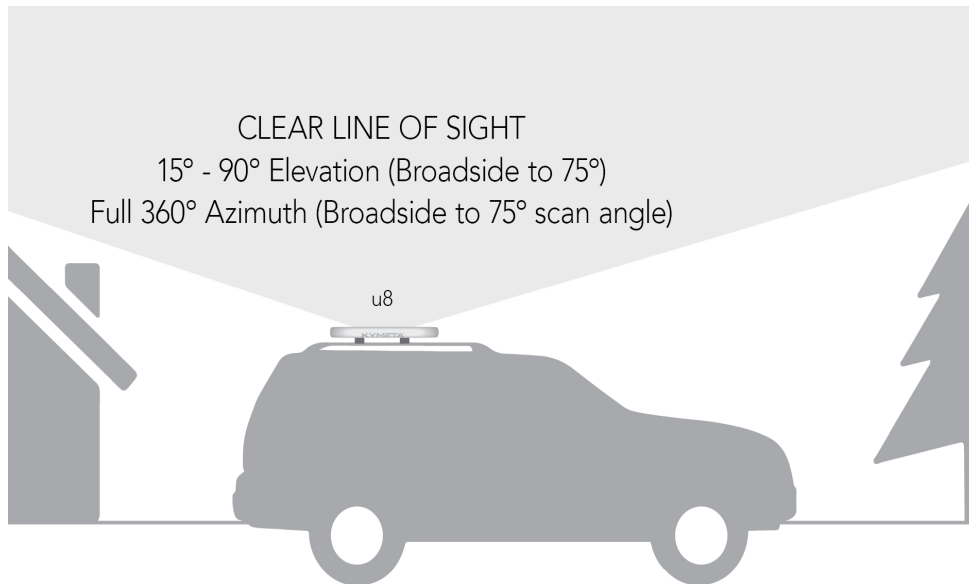

Figure 2. Land-mobile installation

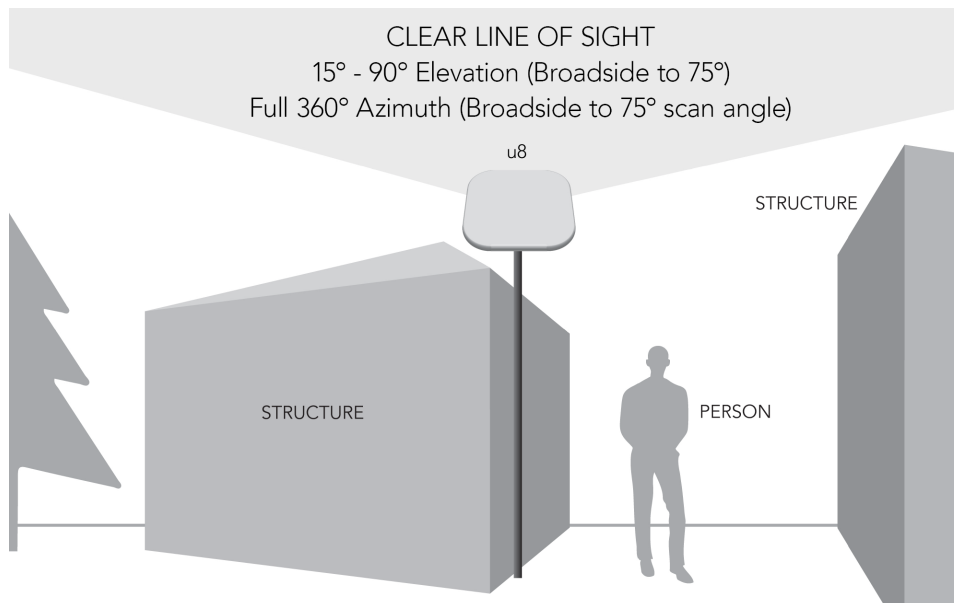

Figure 3. Stationary installation

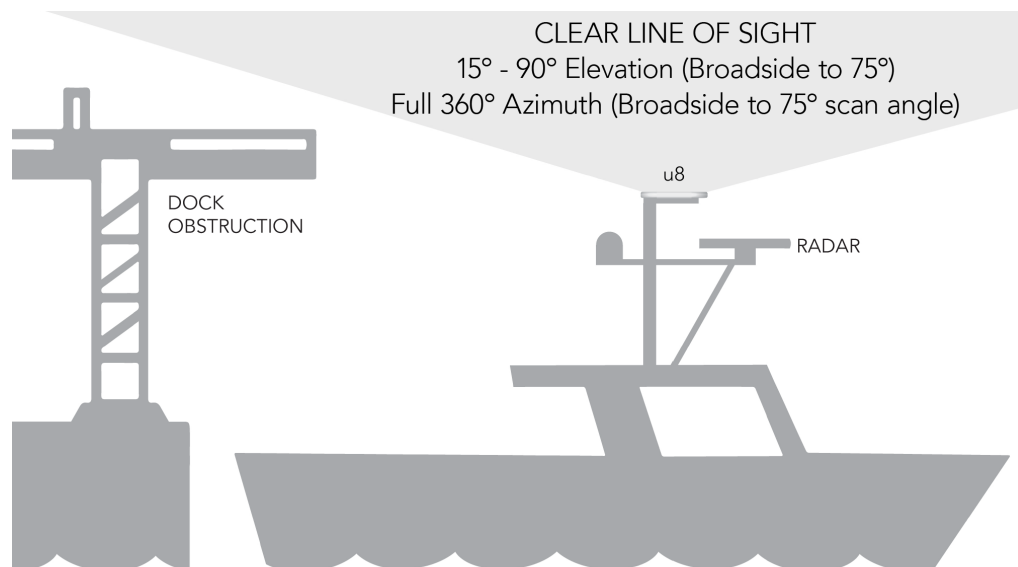

Figure 4. Maritime installation

1.6 Mounting considerations

Any mounting solution designed for the u8 antenna, u8 ODU, or u8 terminal must allow for lateral and vertical thermal expansion and contraction of the unit. Rigid constraint of the unit may result in permanent damage to the unit, including catastrophic failure, and voids the warranty of the u8 product. Kymeta recommends a minimum clearance of 1.5 cm (0.6 in.) of clearance from the antenna/ODU terminal edge to account for this thermal expansion.

- ✦ When mounting the u8, keep at least a 305 mm (12 in.) open distance behind the fans and a minimum single exhaust zone vertically (up or down), horizontally (right or left), or some combination to minimize backpressure.

1.7 Land-mobile installation considerations

For safety to your vehicle and rack system, obey all posted speed limits and traffic cautions. Adapt your speed to the conditions of the road and the load being carried.

1.8 Supported browser

Use Mozilla Firefox to access the Kymeta web-based user interface (UI).

1.9 QR code

The u8 includes a QR code on the antenna communications module next to the LED status panel to show the as-built configuration of the system. The following is an example of the information included in the QR code:

```
PRODUCT_NAME: (E.G KYMETA U8 GEO TERMINAL, 20W)
PRODUCT_CODE: (E.G U8911-11113-P)
PRODUCT_SN: (E.G ABQ000K200624006)
ANTENNA_SN: (E.G ABP511K200710025)
MODEM_SN: (E.G 017806)
HD1_SN: (E.G 2937E989A746)
HD1_IMEI: (E.G 353533100504078)
IP_ADDRESS: 192.168.44.2
SIM_ID: (E.G. 890034011009200000000000000000016259)
```

2 u7-to-u8 upgrade kit installation considerations

This section describes u7-to-u8 terminal upgrade considerations. For the major design features of the u8 terminal refer to [1 Introduction and general considerations](#).

2.1 Physical and mounting considerations

- » The footprint of the u8 terminal is 89.5 cm × 89.5 cm × 14 cm (35.2 in. × 35.2 in. × 5.5 in.), which is slightly larger than the u7 footprint. Before you begin installation of the u8, ensure you have enough mounting space for the increased footprint size.

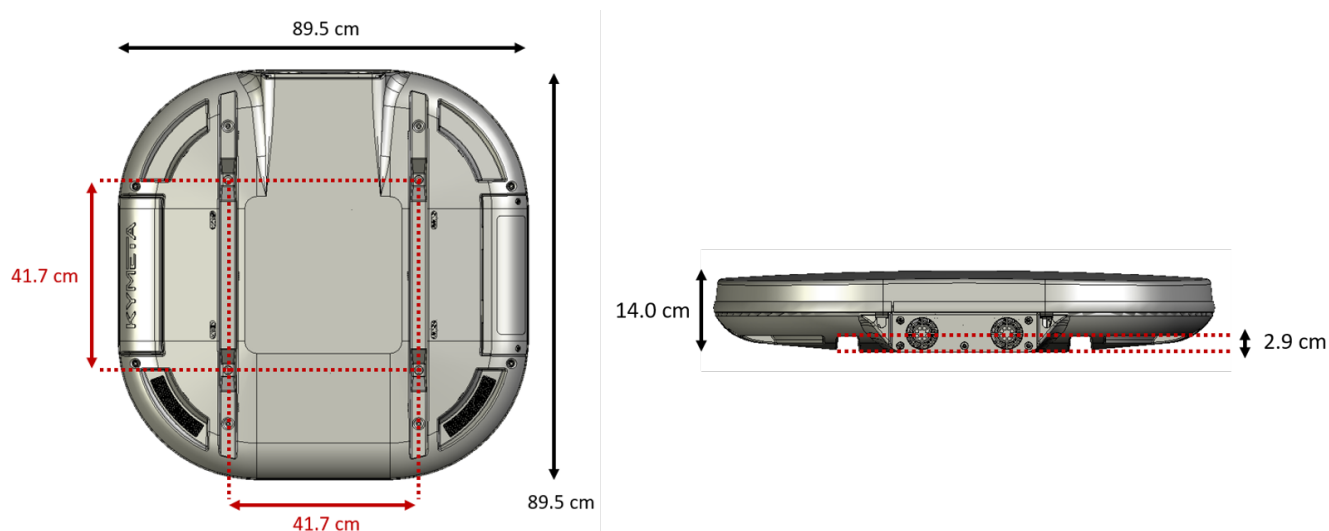

Figure 5. u8 terminal dimensions

- » The u8 has a different mounting hole pattern than the u7. To mount the u8, you need to purchase the universal mounting plate (U8ACC-00004-0) or build your own mounting solution. For more information on the universal mounting plate and mounting the u8, see [5.2 Mount the u8 terminal](#) and [700-00143-000 Universal mounting plate installation instructions](#).
- » The physical design of the u8 requires enough space around the u8 to avoid blockage of some elements. This includes the following:
 - » The u8 has all cables routed out the side next to the fans. Ensure when mounting and installing the u8 that this space isn't blocked.
 - » The u8 terminal fans are critical to proper thermal function; refer to [1 Introduction and general considerations](#) for terminology. When mounting the u8, keep at least a 305 mm (12 in.) open distance behind the fans and a minimum single exhaust zone vertically (up or down), horizontally (right or left), or some combination to minimize backpressure.
 - » The u8 terminal access panel on one side is removable for LED/admin Ethernet access. You need to ensure that this panel is reachable after you have mounted and installed the u8.

2.2 Cabling considerations

- » The u8 terminal comes with the Ethernet jumper cable that extends the Ethernet connection outside of the shroud. For more information on u8 cabling and the u8 products cable extension kit, see [Appendix A. Kymeta u8 terminal cabling diagram](#)
- » The u7-to-u8 terminal upgrade kit ships with the u8 customer Ethernet cable (25' length). If you want to use this LAN connection, you need to remove the shroud and install the Ethernet jumper cable.
- » The u7-to-u8 terminal upgrade kit ships with a power jumper cable. If you want an AC solution, you need to purchase the AC-to-DC power kit (U8ACC-00002-0).
- » If you are replacing a u7 terminal mounted on a vehicle, consider purchasing a u8 vehicle power kit (U8ACC-00001-0).

2.3 Power considerations

- » The u7 is configured by default to be used with an AC power via the I/O box or onboard power supply and requires a 40 VDC power source.
- » The u8 is configured by default to use a DC power source and requires a 12 VDC to 36 VDC power source. To use an AC power source for the u8, purchase the AC-to-DC power kit (U8ACC-00002-0).

For more information on the power specifics of the u8, refer to [5.1.2 AC power source instructions](#)

2.4 u7 product disposal

If you want to dispose of your u7 product, follow your local disposal regulations.

2.5 u7 product warranty

Warranty for the u7 is terminated 30 days after the u8 ships.

3 Unbox the u8 terminal

1. Clear a **flat surface**: place a piece of foam, fabric, or non-abrasive material on the clean flat surface to prevent marks or damage to the face of the u8 antenna.
2. Unpack the terminal. To open the box, lay it flat on an open area where it's easy for one person to stand on each side near the clean assembly surface.
3. With two people (one person on each side), lift the u8 out of the case, keeping the antenna parallel to the floor, and lay the antenna face down on the clean flat surface. Place a piece of foam, fabric, or non-abrasive material on the clean flat surface to prevent marks or damage to the face of the antenna.

 The u8 terminal box includes a large grey foam piece to protect the top of the u8 during transportation. Use this as a protective pad when working on the u8.

4 Open the u8 shroud

 This step is optional.

The u8 shroud includes the fan panel, the access panel, drain slots, and the egress for the cable bundles. Before installing and mounting the unit, you can open and remove the shroud without affecting the warranty or IP-rating. Open the shroud if you need to access the connections or cables inside including the RX, TX, and Ethernet cable jumper or the power cable connector to install an AC-to-DC power kit.

To open the shroud, follow the instructions below:

1. Place Kymeta u8 terminal shroud-up on a soft surface to protect the radome.
2. Remove the (×8) M6 fasteners on the shroud using the T20 Torx driver.

 The cable glands on either side of the fan panel are not fixed to the shroud and must be removed to modify power cable routing.

3. Gently lift the shroud until the fan cable connector is accessible. Disconnect the section attached to the fans and fan panel by unlocking the outdoor-rated Ethernet connector and gently pulling to release. Then, fully remove the shroud and place it aside.

 Removing the fan panel from the shroud is not necessary.

4. Access the connections or cables inside including the RX, TX, and Ethernet cable jumper or the power cable connector to install an AC-to-DC power kit. If you have a u8 ODU, refer to [6.1 Connect the cables to the u8 ODU](#) to connect all cables before replacing the shroud.
5. Reconnect the fan cable, and then set the shroud back in place and ensure the cable glands are properly secured. Pay special attention to the seating of the shroud, and the location of the cables beneath it. Ensure that the RF, power, and fan connector cables are clear of the 4 mounting points. Re-install the (×8) M6 fasteners from Step 2 and torque to 7.0 N-m (5.16 ft.-lb.). These fasteners have a nylon patch so Loctite is not required.

For more information, refer to [6.1 Connect the cables to the u8 ODU](#), [Appendix A. Kymeta u8 terminal cabling diagram](#), and [Appendix B. Kymeta u8 ODU cabling diagram](#).

For information on the available u8 accessory kits to support your installation needs refer to section [Appendix D: u8 accessories available for purchase](#).

5 Install the u8 terminal

5.1 Get the u8 terminal ready

5.1.1 Mobile platform instructions

Installing the u8 terminal on a car is similar to installing an audio amplification system. Kymeta recommends contacting an authorized auto shop to install the u8 terminal on your car.

The u8 terminal accepts 12 V to 36 V DC maximum power and integrates with most platforms.

Kymeta offers u8 vehicle power kit (U8ACC-00001-0) for land-mobile installation of the u8 terminal. Depending on your installation specifics, follow the *700-00111-000 Kymeta u8 terminal vehicle power kit installation instructions* provided with the power kit.

5.1.2 AC power source instructions

The u8 terminal accepts DC voltage, so you need an AC-to-DC power supply to power the antenna with a standard wall outlet. Kymeta sells an IP-67-rated AC-to-DC power kit (U8ACC-00002-0) as an accessory to the u8.

1. Open the shroud as described in section [4 Open the u8 shroud](#).
2. For physical Ethernet access to the data network of the u8, the terminal arrives with the Ethernet jumper cable (W57) pre-attached to the communications module. If not pre-attached, remove (W57) from attached bag, and connect the weatherized Ethernet jumper cable (W57) to the data port on the communication module.
3. Install the AC-to-DC power kit (U8ACC-00002-0). Follow the *700-00142-000 AC-to-DC power kit installation instructions* shipped with the kit.
4. Set the shroud back as described in Step 5 in section [4 Open the u8 shroud](#).

5.2 Mount the u8 terminal

5.2.1 Mobile platform instructions

Kymeta offers u8 vehicle mounting kit (U8ACC-00003-0) for land-mobile installation of the u8 terminal. Follow the instructions from the *700-00141-000 Kymeta u8 vehicle mount kit installation guide* provided with the mounting kit.

5.2.2 Stationary platform instructions

Kymeta offers universal mounting plate (U8ACC-00004-0) for stationary installation of the u8 terminal. Follow the instructions from the *700-00143-000 Universal mounting plate installation instructions* provided with the mounting kit.

5.3 Power on the u8 terminal and access the antenna

1. Ensure the terminal is in place with view of the sky, preferably, according to the guidelines in [1.5 Site selection](#).
2. Check that all power cables are connected.
3. Power on the u8 terminal. You may hear the shroud fans power up, and then reduce speed.

 The Kymeta u8 antenna operates on 12 VDC to 36 VDC maximum. Exceeding 36 VDC may cause damage to the equipment and is not covered under warranty.

4. Connect to the antenna's Wi-Fi. After 1-3 minutes, the Wi-Fi SSID of the terminal multi-WAN device becomes active and available to interact with the terminal via the Kymeta Access application or Kymeta software administrative web-based user interface (UI). Refer to the [700-00139-000 Kymeta™ u8 antenna software user guide](#) for details. *Note: #### are four digits unique for each terminal.*

Antenna Wi-Fi	SSID	Default password	Purpose
Administrative access Wi-Fi	u8_Admin_####	Gen2 for the World. <i>(Including the period)</i>	Terminal administration including accessing the Kymeta antenna web-based UI and modem commissioning
Data access Wi-Fi	u8_Internet_####	Kymeta brings us together. <i>(Including the period)</i>	Applications like internet browsing or streaming services that don't permit operations through a VPN
Data access Wi-Fi with session continuity	u8_SFC_####	Kymeta brings us together. <i>(Including the period)</i>	Applications that require continuity like Wi-Fi calls or video conferences

5. *(optional)* Access the u8 system for administration or monitoring. Full system status is available through the Kymeta Access application. This application also connects you to other system components for Administration. Refer to [Appendix F: Device login information](#) for details.

 Change your passwords using the Kymeta Access application. Leaving the passwords as the default is a security risk.

Physical access to the administrative network of the u8 is available by connecting to the Admin Ethernet port after opening the access panel on the side. You need to set the static IP address of your administrative device to connect to the antenna IP address 192.168.44.2 (e.g. 192.168.44.30). Operation in motion with the access panel open or with an administrative Ethernet connection is not recommended. Refer to [7.1 Open the shroud access panel](#).

In the u8 terminal configuration, you have the option to install a second SIM for terrestrial communications. Refer to [5.5 Set up the u8 terminal secondary SIM](#) for details.

5.4 Provision and commission the u8 terminal with Kymeta™ Broadband services

Contact support@kymetacorp.com to request a commissioning window. Provide your terminal serial number, contact name and number, and requested commissioning window 07:00-18:00 PT (UTC-8).

Kymeta support will provision your terminal and provide you options files before the call, which you will load with Kymeta support during your commissioning window.

Before commissioning, ensure your administrative laptop has access to the u8 administrative network, either with the physical access under the access panel, or wirelessly on the Admin Wi-Fi network. See [Appendix F: Device login information](#) for login information.

During your commissioning window, ensure your terminal has a clear view of the sky, and then contact Kymeta support according to the instructions provided by the support team during the confirmation of your commissioning time. They will guide you through the process of bringing your terminal on satellite for the first time.

5.4.1 Provision and commission the u8 terminal without Kymeta™ Broadband services

For instructions refer to the *700-00139-000 Kymeta™ u8 antenna software user guide*, section "Software Commissioning Mode support".

5.5 Set up the u8 terminal secondary SIM

In the u8 terminal configuration, you have the option to install a second SIM for terrestrial communications. To install a second SIM card, do the following:

1. Remove the shroud access panel as described in [7.1 Open the shroud access panel](#).
2. Use a screwdriver to remove the SIM cover.

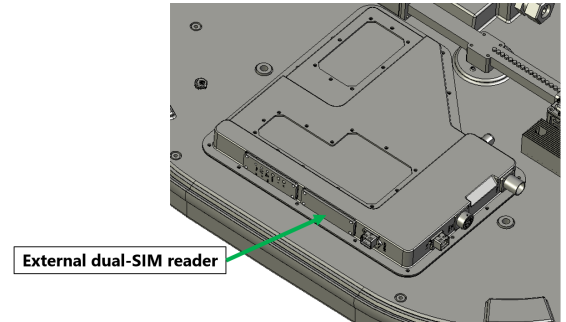

3. Insert the second SIM in slot 2 by sliding the metal lock mechanism to the "open" position. Flip out the empty SIM card holder "2" and insert the second SIM.
4. Return the SIM holder to its original position ensuring that the card is aligned properly and that the electronic pad of the card mates with the contacts on the terminal. Then, slide the metal locking mechanism back into position.



5. Attach the SIM cover with the four M4 x 6 mm screws.
6. Attach the access panel with the two captive pan washer screws M6×16mm. Use a T20 Torx drive.
7. Enable second SIM WAN through Kymeta Access application or portal or contact Kymeta customer support.

Adjust priority between all SIMs and satellite through the Kymeta Access application.

6 Install the u8 ODU

6.1 Connect the cables to the u8 ODU

Current packaging of the ODU does not require complete removal of lower shroud to install the RX and TX cables. The u8 terminal ships with the RX, TX, and Ethernet cables attached; however, the cable gland is not installed for packaging reasons. To install the cable gland, do the following:

1. Flip the ODU upside down on a soft surface to protect the hydrophobic coating (see section [1 Introduction and general considerations](#)).
2. Remove the two M6 screws closest to gland opening (see the figure below).
3. Lift the lower shroud and attach of the gland over the RX and TX cables and between the upper and lower shroud.
4. Once the gland is positioned, lower the shroud and reattach the two M6 screws.

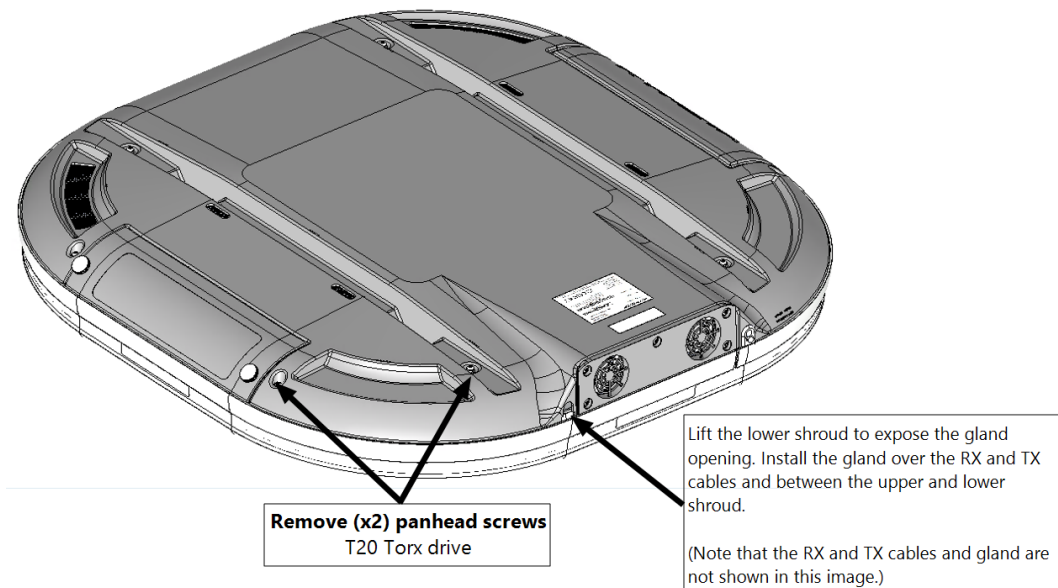

✎ Check that all screws are tight before lifting the ODU.

✎ Kymeta recommends that installers, integrators, and handlers of the u8 do not lift or hold the u8 by using any of the RF chain as a handle or grip, or by any mounted components or cables. Always lift the u8 by the corner handles.

6.2 Mount the u8 ODU

Mounting the u8 ODU is the same as mounting the u8 terminal. Refer to [5.2 Mount the u8 terminal](#) for details.

6.3 Power on the u8 ODU and access the antenna

1. Ensure the ODU is in place with view of the sky according to guidelines in [1.5 Site selection](#).
2. Check that all cables are connected:
 - a. RX and TX cables are connected to the modem.
 - b. The Ethernet cable is connected to administrative port of modem or a network switch.
 - c. The power cable is connected to power source.
3. Power on the u8 ODU and external modem. You may hear the shroud fans power up, and then reduce speed.

 The Kymeta u8 antenna operates on 12 VDC to 36 VDC maximum. Exceeding 36 VDC may cause damage to the equipment and is not covered under warranty.

4. After modem has booted, the antenna becomes accessible via wired Ethernet.
 - a. Set your local IP device to static IP address 192.168.0.11.
 - b. Access the Kymeta web-based UI at IP address 192.168.0.10. See [Appendix F: Device login information](#) for details, and refer to *700-00139-000 Kymeta™ u8 antenna software user guide* for web-based UI details.

A second physical Ethernet connection to the u8 ODU is available after opening the access panel on the side. Operation in motion with the access panel open or with an administrative Ethernet connection is not recommended. See section [7.1 Open the shroud access panel](#) for details on accessing the shroud access panel.

6.4 Provision and commission the u8 ODU

For instructions refer to the *700-00139-000 Kymeta™ u8 antenna software user guide*, section "Software Commissioning Mode support".

7 Obtain u8 antenna status information

After the terminal has booted, you can obtain status information in several ways.

1. In a terminal configuration, utilize the Kymeta Access application to view full terminal status.
2. In a terminal or ODU configuration, open the shroud access panel as described in [7.1 Open the shroud access panel](#) to view status LEDs. Solid green LEDs indicate normal functioning, and blinking blue LEDs indicate connectivity. Refer to [Appendix C. LED status indicators](#) for full LED status indicator definitions.
3. In a terminal or ODU configuration, open the shroud access panel as described in [7.1 Open the shroud access panel](#) and connect an Ethernet cable to the available port. This Ethernet connection provides Kymeta Administrative web-based UI access according the directions in the section above relevant to your configuration.

Refer to *700-00139-000 Kymeta™ u8 antenna software user guide* for details on interacting with the features of the Kymeta antenna. The software user guide provides you with details on all available features and modes of operation.

7.1 Open the shroud access panel

The shroud access panel provides access for:

- » Viewing LED status lights for the antenna, modem, and/or multi-WAN – refer to for information about what each LED state indicates.
- » Accessing Ethernet port for physical administrative access
- » Utilizing the reset functionality of the antenna, modem, and/or multi-WAN
- » Adding a SIM

To open the shroud access panel, do the following:

1. Remove the (×2) Thumb Screws M6×12mm.
2. Slide the panel toward you to remove.

⚠ The access panel does not hinge. Downward pressure may damage the panel.

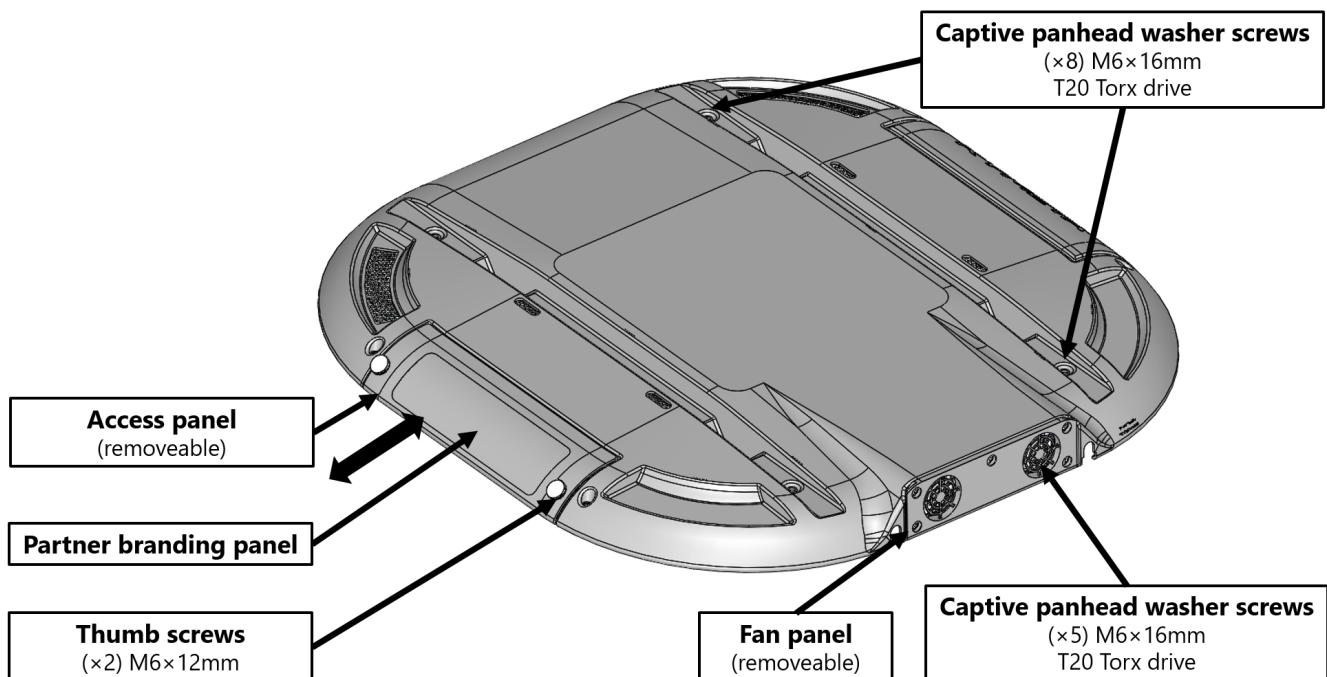

⚠ Operation in motion with the access panel removed or open is not recommended.

8 Set up u8 antenna orientation

When in motion, the antenna's yaw (heading), relative to north, is provided by the GPS heading. The Kymeta u8 antenna out-of-the-box configuration assumes that the X axis of the antenna is aligned with the heading vector of the vehicle. If this is not the case, you can set the vehicle-to-ant-yaw value to inform the antenna of the offset. Set the offset correctly to expedite acquisition of the satellite while in motion.

 If the offset is not set or is set incorrectly, the antenna can acquire the satellite, but it may take longer and will result in more out-of-network time.

In the figure below, the antenna is correctly aligned, using the antenna's default value of zero.

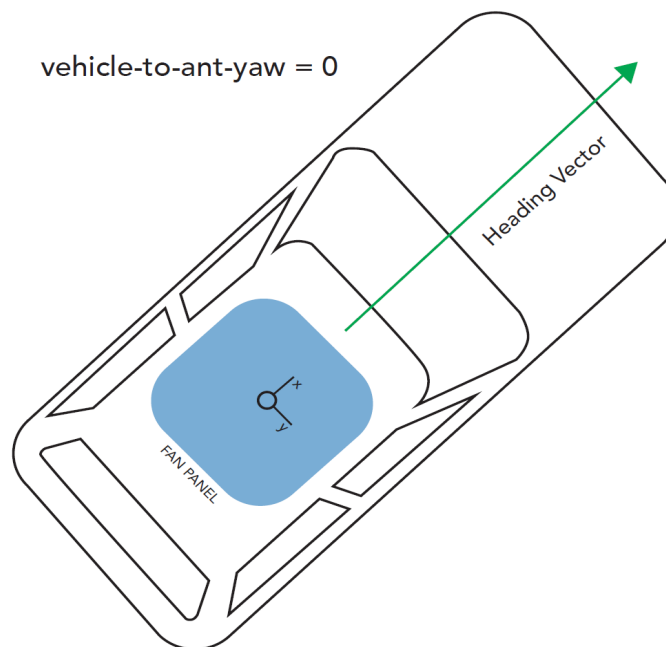

 Make sure the Kymeta logo is front-facing and the fans are facing towards the rear of the car.

For an unaligned antenna, set vehicle-to-ant-yaw to the angle between the X axis and the heading vector as in the figure below. The range is from -360° to 360° with positive angles representing a clockwise rotation of the antenna from the vehicle heading vector.

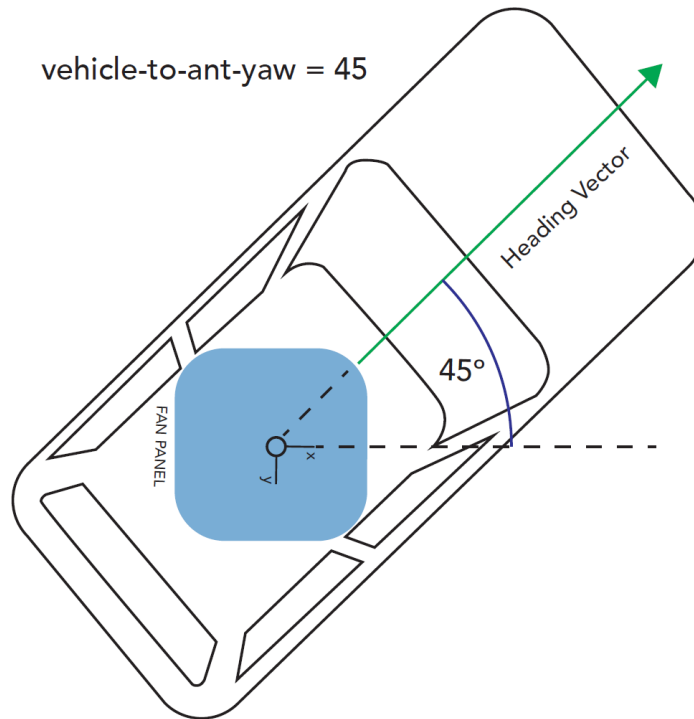

✎ Ensure vehicle-to-antenna-roll and vehicle-to-antenna-pitch are set to their default values of 0. The onboard accelerometers measure these values directly, so no offset is required.

You can adjust the vehicle-to-antenna-yaw offset value using the antenna's API. Navigate to **Help > API Documentation > /setup/vehicle-to-ant**. Then, set the necessary value. Refer to *700-00159-000 Kymeta™ u8 antenna public RESTful application programmers' interface reference* for further information on using the RESTful API.

✎ The vehicle-to-antenna-yaw value will persist through software updates once set, but it will be removed with a factory reset of the antenna.

✎ For an adjustment to the vehicle-to-antenna-yaw to expedite acquisition under motion, the offset must be accurately estimated to within 3°.

9 Network interfaces

The u8 terminal will ship to you with the following network interfaces:

Network Interface	Network Setting	Terminal value (as shipped)
Local network	IP Mode	static
Local network	IP Address	192.168.44.2
Local network	Netmask	255.255.255.0
Local network	Gateway	blank/empty
Local network	DNS Server	blank/empty
Admin VLAN	IP Mode	static
Admin VLAN	IP Address	192.168.45.2
Admin VLAN	Netmask	255.255.255.0
Admin VLAN	Gateway	blank/empty
Admin VLAN	DNS Server	blank/empty
Data VLAN	IP Mode	static
Data VLAN	IP Address	10.12.12.2
Data VLAN	Netmask	255.255.255.0
Data VLAN	Gateway	10.12.12.3
Data VLAN	DNS Server	8.8.8.8

 Failure to utilize the Data VLAN settings as shipped will result in connectivity issues with the antenna on all forms of u8 terminal connectivity except the wired Admin Ethernet Port as well as elimination of OTA Metric transmission.

The u8 antenna and u8 ODU will ship to you with the following network interfaces:

Network Interface	Network Setting	ODU value (as shipped)
Local network	IP Mode	static
Local network	IP Address	192.168.0.10
Local network	Netmask	255.255.255.0
Local network	Gateway	blank/empty
Local network	DNS Server	blank/empty
Admin VLAN	IP Mode	static
Admin VLAN	IP Address	192.168.45.2
Admin VLAN	Netmask	255.255.255.0
Admin VLAN	Gateway	blank/empty
Admin VLAN	DNS Server	blank/empty
Data VLAN	IP Mode	dhcp
Data VLAN	IP Address	N/A
Data VLAN	Netmask	N/A
Data VLAN	Gateway	N/A
Data VLAN	DNS Server	N/A

 Failure to utilize the Data VLAN settings as shipped will result in elimination of OTA Metric transmission

If you utilize the antenna reset button, and depress the button for 5 seconds or longer, the u8 reverts to baseline network configuration:

Network Interface	Network Setting	Baseline configuration (after reset)
Local network	IP Mode	static
Local network	IP Address	192.168.0.10
Local network	Netmask	255.255.255.0
Local network	Gateway	blank/empty
Local network	DNS Server	blank/empty
Admin VLAN	IP Mode	static
Admin VLAN	IP Address	192.168.45.2
Admin VLAN	Netmask	255.255.255.0
Admin VLAN	Gateway	blank/empty
Admin VLAN	DNS Server	blank/empty
Data VLAN	IP Mode	dhcp
Data VLAN	IP Address	10.12.12.2
Data VLAN	Netmask	255.255.255.0
Data VLAN	Gateway	10.12.12.3
Data VLAN	DNS Server	8.8.8.8

If you utilize the antenna reset button, be sure to replace the network configuration as defined by the tables above. Utilize the Kymeta web-based UI at **Settings** > **Network** to adjust the values to match the as-shipped configuration or as required. It is recommended to utilize the Admin Wired Ethernet Port to access and make corrections to reduce connectivity issues

10 Manage u8 antenna automatic reboot

The u8 antenna automatically reboots every 21 days since the previous automatic or manual reboot. To see the countdown until the next reboot or disable the automatic reboot in the u8 web-based user interface, go to the **Settings** page > **System** tab, and then view the **Auto Reboot** field.

To opt out of the automatic 21-day reboot, see *700-00139-000 Kymeta™ u8 antenna software user guide*.

11 Manage over-the-air (OTA) updates

The u8 antenna requires factory-installed software to operate, which is pre-installed at the factory. Users can manage OTA updates as new software releases in the Kymeta Access portal.

11.1 OTA update process

1. The antenna checks on start-up to determine if an OTA update is available. The antenna performs this check through secure web services calls to Kymeta Access portal.
2. If the antenna is eligible for an update, a package is downloaded and installed. If the antenna is not eligible, no action is taken.

The u8 operates normally during the OTA update process. The newly installed software version takes effect on the next restart of the antenna. You will experience a brief internet outage during the restart.

 It is not possible to monitor the status of the OTA download. However, you can verify the update has completed by the software version number displayed in the top right corner of the web-based user interface. Refer to *700-00139-000 Kymeta™ u8 antenna software user guide* for details.

If the OTA update download is interrupted, the u8 retries up to 10 times to successfully download the update package. You will not see any indication of the activity. If after 10 attempts the download does not complete, it retries on the next restart.

If the OTA update install is interrupted, the software reverts to the original version, and the antenna retries installation on the next restart.

11.2 Software rollback

Contact [*Customer support*](#) if you want to roll back to a previous software version.

12 Troubleshoot the u8

This section describes common issues and basic troubleshooting steps. If these steps fail to resolve your issue, contact Customer support.

1. The Wi-Fi never appears available to my device.
 - a. Check that the unit has power.
 - b. Open the access panel and check LED status indicators. If any indicators are yellow or red and/or flashing rapidly, contact Kymeta customer support. Refer to [Appendix C. LED status indicators](#) for LED status indicator definitions to assess if an error condition has been encountered. If any LEDs indicate an error condition, contact Kymeta customer support.
2. My device is not able to access the IP addresses of the antenna or modem when connected via Wi-Fi.
 - a. Check the IP settings on your machine. The Wi-Fi should provide you an IP address either in the 10.10.15.XX range (Admin Wi-Fi) or in the 192.168.55.XX range (Internet Wi-Fi). If you did not receive any of these IP addresses, turn off and on your Wi-Fi or try connecting to the other Wi-Fi network.
3. My device is not able to access the IP addresses of the antenna or modem when connected via physical Ethernet.
 - a. Check that you are connected to the expected Ethernet port (Admin or Data in the terminal configuration).
 - b. Check that your machine has a static IP address that can address the antenna at its IP address indicated in [5.3 Power on the u8 terminal and access the antenna](#).
4. I changed network configuration of one of the devices in my terminal and now cannot see it.
 - a. Use the **Reset** button under the access panel to reset the unit to baseline configuration, then utilize the tables in section 9 to return the unit to its as-shipped network configuration.
5. The terminal is powered on, but the modem is not responding.
 - a. Ensure your iQ 200 software is updated to version 21.0.4.0. If the modem still remains unresponsive, contact Customer support.

13 Replace components

Kymeta offers a variety of field replaceable units (FRUs). Refer to [Appendix E: u8 ODU and u8 terminal parts available for purchase](#) for details. For replacement instructions, refer to the documentation shipped with the FRUs.

14 Clean the u8

Prior to cleaning any part of the u8, ensure it is powered off.

14.1 General cleaning

Blow or rinse off loose debris first, and then apply a cleaning agent and use a clean, soft towel to clean the stained area. Avoid scrubbing and do not use abrasive materials when cleaning the terminal components. Avoid exposing rubber parts (for example, gaskets) to alcohol or alcohol-based cleaners, for these can deteriorate the rubber.

To gently clean all **connectors**, use a soft bristle acid brush or cotton swab with isopropyl or denatured alcohol. Take extra care when cleaning RF air-dielectric connectors and don't damage, bend, nick, push in, or pull out the center connector as this can affect your signal. Carefully clean any surface corrosion on the exterior of the connector. Do not scrape or overscrub the connector as this can damage the connector coating and render it more susceptible to corrosion. Ensure connectors are completely dry before reconnecting.

To clean lightly oxidized **screws**, use a soft bristle brush and isopropyl or denatured alcohol. Replace heavily corroded or oxidized screws when possible.

14.2 General cleaning agents

Clean fingerprints, smudges, salt spray, and light marks with a soft sponge and a mild cleanser that does not use abrasives, acids, and/or biocides are added.

For more difficult stains, isopropyl alcohol products (CAS Number 67-63-0) or LPS Precision Clean Multi-Purpose Cleaner (degreaser at 10 to 1 dilution) can be used, however the hydrophobic coating should be reapplied after cleaning.

14.3 Hydrophobic coating reapplication

The u8 comes with a hydrophobic coating applied to the radome. For best performance Kymeta recommends reapplying the coating every 6-12 months. Kymeta sells the hydrophobic coating reapplication kit (U8ACC-00028-0) as an accessory. For additional information on this coating or for purchasing this material, see the following site: <https://chemonaworld.com/product/chemona-multi-coat/>. Refer to the 700-00175-000 *Hydrophobic coating kit application instructions* for details.

15 Package the Kymeta u8 terminal

 Kymeta recommends boxing the u8 terminal in the original packaging. If you need to return a terminal, Kymeta provides the replacement terminal first. Use the packaging from the replacement terminal to ship the original one back.

The order of the following steps may vary depending upon your mounting structure. Always follow the guidelines in *700-00122-000 Kymeta™ u8 products safety and handling guide* for best practices.

1. Power off the terminal using the power switch on the power interface box.
2. Carefully disconnect and cap the power cable and Ethernet cable, being mindful of pins and connectors.
 - a. Ensure cable ends do not drop into water or dirt.
 - b. Dry off cables and coil them into the box, binding with cable ties.
 - c. Do not leave adapters on cables.
3. Remove the u8 from the mounting structure and place face-down on a non-abrasive surface for safe and easy access.
4. Dry off all equipment and remove any debris.
5. Place the u8 back into the shipping compartment in the original cardboard box.
 - a. Secure any loose items (e.g., screws, tools, cable ends).
 - b. Close the box.
6. Place the u8 original shipping box inside a reusable container.
7. Close the container and fasten the latches carefully.

16 Customer support

Contact Kymeta customer support at support@kymetacorp.com or call Kymeta **1-855-525-6638** for urgent issues.

17 Revision history

Revision	Change
A	Initial Production version.
B	Enhanced installation instructions.
C	Minor corrections.
D	Added u7-to-u8 terminal upgrade kit consideration to section 2.
E	Updated drawings to reflect latest iteration of the u8. Updated Appendix A and Appendix B.
F	Updated section 1.1 to include mention of hazard zones software feature.
G	Updated instructions for changing default passwords.

18 Copyright and trademark information

©2021 Kymeta Corporation. All Rights Reserved. KYMETA, KYMETA CONNECT, MAKING MOBILE GLOBAL, and CONNECTED BY KYMETA are trademarks of Kymeta Corporation, with registrations or pending applications in the U.S. and/or other countries. All other trademarks are the property of their respective owners.

Appendix A. Kymeta u8 terminal cabling diagram

Six field-replaceable external cables [1, 2, 3, 4, 5, and 6] reside under the u8 terminal shroud. The fan panel cable [8] can be replaced without removing the shroud. The power jumper cable [1] and Ethernet jumper cable [2] move connection interfaces outside the shroud to improve installation experience.

u8 Terminal Cabling Diagram

1. Power jumper cable (W38C or W38B)
2. Ethernet jumper cable (W57)
3. Fan power and control jumper cable (W47A)
4. BUC power, M&C cable (W44)
5. RX LNB cable (W46)
6. TX cable (W43)
7. Power main cable (W38A)*
8. Fan panel cable (W47B)

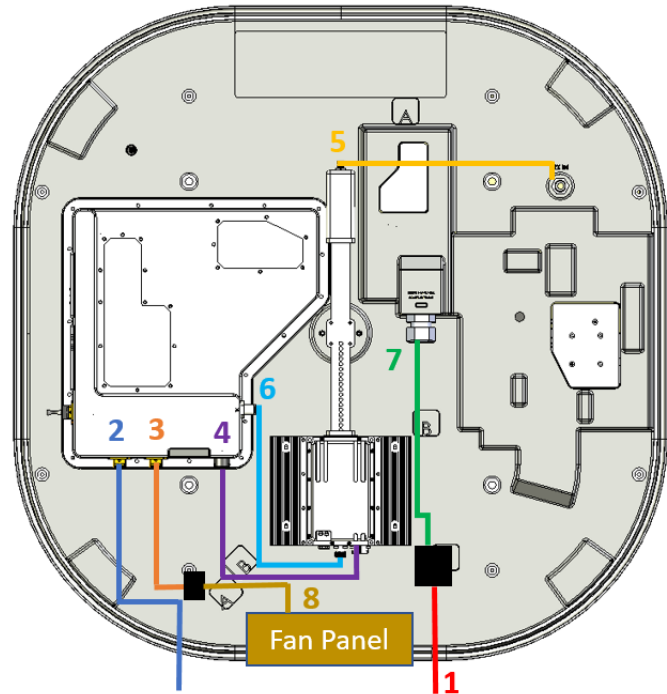

*The power main cable (W38A) is not replaceable.

Cable name and product code	Cable description
Power jumper cable (W38C) (U8ACC-00017-0)	This cable is unterminated and can be connected to the u8 vehicle power kit (U8ACC-00001-0) using in-line splice blocks. If you want to use the AC-to-DC power kit (U8ACC-00002-0), replace the power jumper cable (W38C) (U8ACC-00017-0) with the cable provided with the power jumper cable (W38B) (U8ACC-00042-0) kit.
Power jumper cable (W38B) (U8ACC-00042-0)	This cable can be connected to the AC-to-DC power kit (U8ACC-00002-0). It overrides the remote power trigger (ACC) function.
Ethernet jumper cable (W57) (U8ACC-00018-0)	This cable connects the communication module to port 1 on the modem. The Ethernet port is for a standard 10/100/1000 network and is the primary monitor and control (M&C) port. It supports multiple protocols for a web server (GUI), ACU-modem Interface (OpenAMIP), and an M2M (machine-to-machine) RESTful API. Installation engineers can make multiple connections with an external switch.

Cable name and product code	Cable description
Fan power and control jumper cable (W47A) (U8ACC-00020-0)	This shielded Ethernet cable provides power and control to the fan panel. Since this cable supplies power, you cannot replace it with a standard non-POE Ethernet cable. Disconnect this cable at the outdoor-rated RJ45 connection halfway between the communication module and fan panel before removing the shroud entirely. The cable is attached to the fan panel cable (W47B).
BUC power, M&C cable (W44) (U8ACC-00019-0)	This cable connects the communication module and BUC. This cable provides power to the BUC and communication to set attenuation, mute, and read output power.
RX LNB cable (W46) (U8ACC-00016-0)	This LMR-195 cable connects the LNB to the antenna RX IN port. The cable requires a right-angle N-type connector at the antenna end to maintain the low profile of the antenna without sharp or protruding cable bends. The cable has standard N-type connectors at each end.
TX cable (W43) (U8ACC-00029-0)	This LMR-195 cable connects the BUC to the communications module carrying the modulated waveform at intermediate frequency. The TX cable works in the frequency range from 950 MHz to 2150 MHz and passes a 10 MHz reference signal to the BUC.
Power main cable (W38A)	<p>This cable is factory-installed and non-removable. The power main cable connects the power jumper cable (W38C) (U8ACC-00017-0) to the embedded power supply.</p> <p>When attaching the power main cable, check the keying: the threads may engage slightly when the connector is rotated by 180° from the correct alignment. Ensure that the threading fully engages. If the power main cable is correctly attached and fully seated, the metal nut at the end of the cable will cover the gasket on the embedded power supply input.</p> <div data-bbox="573 1035 1508 1152" style="border: 1px solid yellow; padding: 5px;"> <p> Incorrectly seating the power connector will result in a short circuit, which will damage the cable and embedded power supply.</p> </div>
Fan panel cable (W47B) (U8ACC-00012-0)	This cable comes as a part of the shroud fan assembly. The cable is attached to the fan power and control jumper cable (W47A). The shroud fan assembly is field replaceable without removing the shroud.

Appendix B. Kymeta u8 ODU cabling diagram

Seven field-replaceable external cables [1, 2, 3, 4, 5, 6, and 8] reside under the u8 ODU shroud. The fan panel cable [9] can be replaced without removing the shroud. The power jumper cable [1], Ethernet jumper cable [2], RX jumper cable [6], and TX jumper cable [8] move connection interfaces outside the shroud to improve installation experience.

u8 ODU Cabling Diagram

1. Power jumper cable (W38C or W38B)
2. Ethernet jumper cable (W57)
3. Fan power and control jumper cable (W47)
4. BUC power, M&C cable (W44)
5. RX LNB cable (W46)
6. RX jumper cable (W58)
7. Power main cable (W38A)*
8. TX jumper cable (W59)
9. Fan panel cable (W47B)

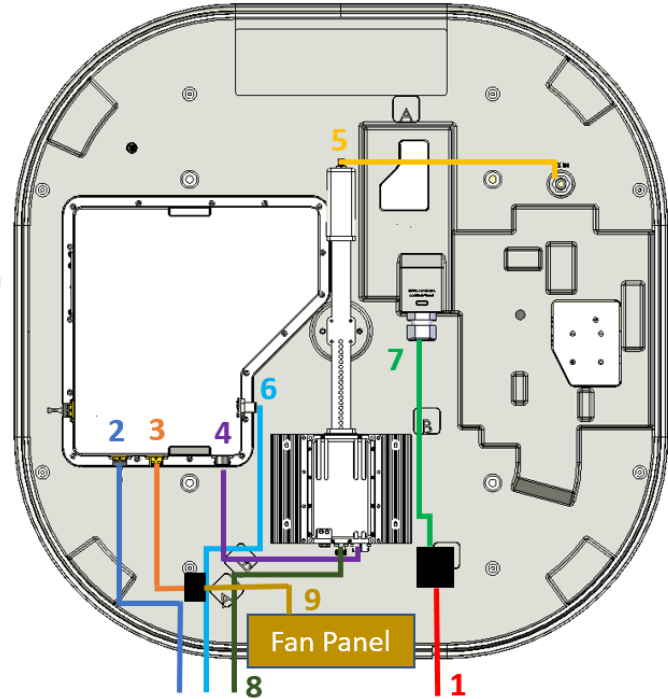

*The power main cable (W38A) is not replaceable.

Cable name and product code	Cable description
Power jumper cable (W38C) (U8ACC-00017-0)	This cable is unterminated and can be connected to the u8 vehicle power kit (U8ACC-00001-0) using in-line splice blocks. If you want to use the AC-to-DC power kit (U8ACC-00002-0), replace the power jumper cable (W38C) (U8ACC-00017-0) with the cable provided with the power jumper cable (W38B) (U8ACC-00042-0) kit.
Power jumper cable (W38B) (U8ACC-00042-0)	This cable can be connected to the AC-to-DC power kit (U8ACC-00002-0). It overrides the remote power trigger (ACC) function.
Ethernet jumper cable (W57) (U8ACC-00018-0)	This cable connects the communication module to port 1 on the modem. The Ethernet port is for a standard 10/100/1000 network and is the primary monitor and control (M&C) port. It supports multiple protocols for a web server (GUI), ACU-Modem Interface (OpenAMIP), and an M2M (machine-to-machine) RESTful API. Installation engineers can make multiple connections with an external switch.

Cable name and product code	Cable description
Fan power and control jumper cable (W47A) (U8ACC-00020-0)	This shielded Ethernet cable provides power and control to the fan panel. Since this cable supplies power, you cannot replace it with a standard non-POE Ethernet cable. Disconnect this cable at the outdoor-rated RJ45 connection halfway between the communications module and fan panel before removing the shroud entirely. The cable is attached to the fan panel cable (W47B).
BUC power, M&C cable (W44) (U8ACC-00019-0)	This cable connects the communication module and BUC. It provides power to the BUC and communication to set attenuation, mute, and read output power.
RX LNB cable (W46) (U8ACC-00016-0)	This LMR-195 cable connects the LNB to the antenna RX IN port. The cable requires a right-angle N-type connector at the antenna end to maintain the low profile of the antenna without sharp or protruding cable bends. The cable has standard N-type connectors at each end.
RX jumper cable (W58) (U8ACC-00022-0)	This short LMR cable with the right-angle connector provides connection from the RX port on the communication module to a connector outside of the u8 ODU shroud. Connect this short cable to a longer coaxial cable connected to the RX port of your modem.
Power main cable (W38A)	<p>This cable is factory-installed and non-removable. The power main cable connects the power jumper cable (W38C) (U8ACC-00017-0) to the embedded power supply.</p> <p>When attaching the power main cable, check the keying: the threads may engage slightly when the connector is rotated by 180° from the correct alignment. Ensure that the threading fully engages. If the power main cable is correctly attached and fully seated, the metal nut at the end of the cable will cover the gasket on the embedded power supply input.</p> <div data-bbox="532 989 1508 1110" style="border: 1px solid yellow; padding: 5px;"> <p> Incorrectly seating the power connector will result in a short circuit, which will damage the cable and embedded power supply.</p> </div>
TX jumper cable (W59) (U8ACC-00021-0)	This short N-type intermediate frequency cable connects the BUC in the ODU to outside the ODU shroud. Connect this short cable to a longer cable connected to the TX OUT of the modem. The TX cable passes a 10 MHz reference signal to the BUC. Kymeta provides an N-type to F-type adapter in the ODU cable kit to connect to the modem.
Fan panel cable (W47B) (U8ACC-00012-0)	This cable comes as a part of the shroud fan assembly. The cable is attached to the fan power and control jumper cable (W47A). The shroud fan assembly is field replaceable without removing the shroud.

Appendix C. LED status indicators

Antenna status LED indicator

LED state	Indication
Off	Antenna not powered
Solid amber	Antenna powered but not successfully booted
Solid green	Antenna powered and successfully booted
Blink green, then solid green	Antenna reset successful

Satellite modem status LED indicator

LED state	Web-based UI indicator	Indication
Off	OFF	Satellite modem not powered
Blinking amber	WAITING	Satellite modem not powered due to attempted operations outside of operating thermal specification
Solid amber	BOOTING	Satellite modem powered but not successfully booted
Fast blink green	ON	Satellite modem successfully booted but LNB not detected
Solid green	READY	Satellite modem successfully booted and LNB detected
Slow blink blue	RX LOCK	RX lock
Fast blink blue	TX ENABLED	TX enabled
Solid blue	CONNECTED	Satellite modem in network
Solid red	ERROR	Fault detected by built-in self test

Multi-WAN status LED indicator

LED state	Web-based UI indicator	Indication
Off	OFF	Multi-WAN not powered
Solid amber	BOOTING	Multi-WAN powered but not successfully booted
Solid green	NO SERVICE	Multi-WAN successfully booted but no WAN available for internet
Solid green	DISABLED	Multi-WAN successfully booted but all WANs are disabled in Multi-WAN configuration

LED state	Web-based UI indicator	Indication
Solid green	DISCONNECTED	Multi-WAN successfully booted but no WAN is reporting status
Slow blink blue	CONNECTING	Multi-WAN connecting to cellular networks
Solid blue	CELLULAR SATELLITE SAT & CELL	Multi-WAN connected to networks
Solid red	ERROR	Fault detected by built-in self-test

Appendix D: u8 accessories available for purchase

Before replacing any terminal components, take inventory to ensure you have all required hardware.

Kymeta provides all hardware for any accessory component for the terminal in accessory kits:

Product name	Description
u8 vehicle power kit, 25' (7.5 M) (U8ACC-00001-0)	Vehicle power kit includes wiring to cleanly and efficiently tie antenna power-on to vehicle power-on.
AC-to-DC power kit, 25' (7.5 M) (U8ACC-00002-0)	AC-to-DC power kit provides a rectifier for powering the antenna from any standard AC power supply.
u8 vehicle mounting kit (U8ACC-00003-0)	Vehicle mount kit includes rails for mounting the u8 terminal or u8 ODU to a vehicle roof rack. It provides a mounting solution for communications-on-the-move, leveraging the Kymeta antenna's low-profile form factor.
Universal mounting plate (U8ACC-00004-0)	Universal mounting plate provides an adapter for all u7 land-fixed systems for the u8 system as well as a static mount for the u8 terminal and u8 ODU.
u8 terminal cable extensions, 25' (7.5 M) (U8ACC-00013-0)	u8 products cable extension kit consists of RX, TX, and Ethernet cables to connect the u8 ODU to an external modem.
u8 terminal MRZR mount (U8ACC-00023-0)	u8 terminal MRZR mount to mount the u8 terminal or u8 ODU to a MRZR vehicle.
u8 hydrophobic coating reapplication (U8ACC-00028-0)	u8 hydrophobic coating kit provides a way to reapply the hydrophobic coating to your radome.

Appendix E: u8 ODU and u8 terminal parts available for purchase

Kymeta offers a variety of u8 ODU and u8 terminal parts listed in the table below. For cable parts available for purchase, refer to [Appendix A. Kymeta u8 terminal cabling diagram](#) and [Appendix B. Kymeta u8 ODU cabling diagram](#).

Product name and product code	Description
u8 antenna diplexer (U8ACC-00006-0)	Low-profile straight diplexer. Technical specifications available in <i>700-00107-000 Kymeta™ u8 products integrator guide</i> .
u8 terminal BUC (U8ACC-00009-0)	Ku-band BUC, 20 W. Technical specifications available in <i>700-00107-000 Kymeta™ u8 products integrator guide</i> .
u8 terminal LNB (U8ACC-00010-0)	Ku-band LNB. Technical specifications available in <i>700-00107-000 Kymeta™ u8 products integrator guide</i> .
u8 antenna shroud (U8ACC-00008-0)	Covers all RF components and contains fans for an integrated thermal management solution. Refer to drawing in <i>700-00107-000 Kymeta™ u8 products integrator guide</i> .
u8 terminal 950MP modem card (U8ACC-00011-0)	Embedded 950MP modem card.
u8 antenna shroud fan assembly (U8ACC-00012-0)	Shroud fan assembly, includes the fan panel cable (W47B).
u8 terminal iQ 200 modem* (U8ACC-00005-0)	Embedded iDirect iQ 200 satellite modem card.
u8 terminal LTE advanced pro Global* (U8ACC-00014-0)	Embedded LTE Advanced Pro modem card (Global configuration).
u8 terminal LTE advanced pro FirstNet* (U8ACC-00015-0)	Embedded LTE Advanced Pro modem card (FirstNet configuration).

*Not available for u8 ODU configurations.

Appendix F: Device login information

The table below is a collection of devices, usernames, and passwords.

⚠ Change your passwords using the Kymeta Access application. Leaving the passwords as the default is a security risk.

Configuration	Device	IP address or SSID	Username	Password	Usage information
Terminal	Wi-Fi	u8_Admin_####	N/A	Gen2 for the World. <i>(Including the period)</i>	Terminal administration including accessing the Kymeta antenna web-based UI and modem commissioning
Terminal	Wi-Fi	u8_Internet_####	N/A	Kymeta brings us together. <i>(Including the period)</i>	Applications like internet browsing or streaming services that don't permit operations through a VPN
Terminal	Wi-Fi	u8_SFC_####	N/A	Kymeta brings us together. <i>(Including the period)</i>	Applications that require continuity like Wi-Fi calls or video conferences
Terminal	Modem	192.168.44.1	admin	P@55w0rd!	Valid before commissioning
Terminal	Modem	192.168.44.1	admin	iDirect	Valid after commissioning when commissioning via Kymeta Broadband
Terminal	Antenna	192.168.44.2	admin	2Cfg^Ant	Access the Kymeta web-based UI.
Terminal & ODU	BUC	Use click-through from Antenna Settings page	admin	admin	Making any changes to BUC configuration may result in unexpected transmission or may cause the BUC to become unreachable.
ODU	Antenna	192.168.0.10	admin	2Cfg^Ant	Access the Kymeta web-based UI.